

1. Product introduction



The ELBC-D50H50SIPM01 spectroscopic detector is a highly integrated detector containing a 2-inch LaBr₃(Ce), silicon photomultiplier (SiPM), summing circuit, preamplifier circuit, and temperature measurement circuit. It features excellent energy resolution, simple operation, compact size, and high reliability. It is widely used in industrial detection, radiological medicine, radiation detection, and other fields.

2. Performance parameter

Parameters	value	Unit
Scintillator type	LaBr ₃ (Ce)	--
Scintillator size	Φ50×50	mm
SiPM size	6×6	mm
Input voltage	+25.5~+29.5	V
Temperature measuring range	-40~+150	°C
Output signal pole type	Positive polarity	/
Energy resolution(¹³⁷ Cs)	≤3.5%	--
Working temperature and humidity	+5~+45	°C

3. External dimensions diagram

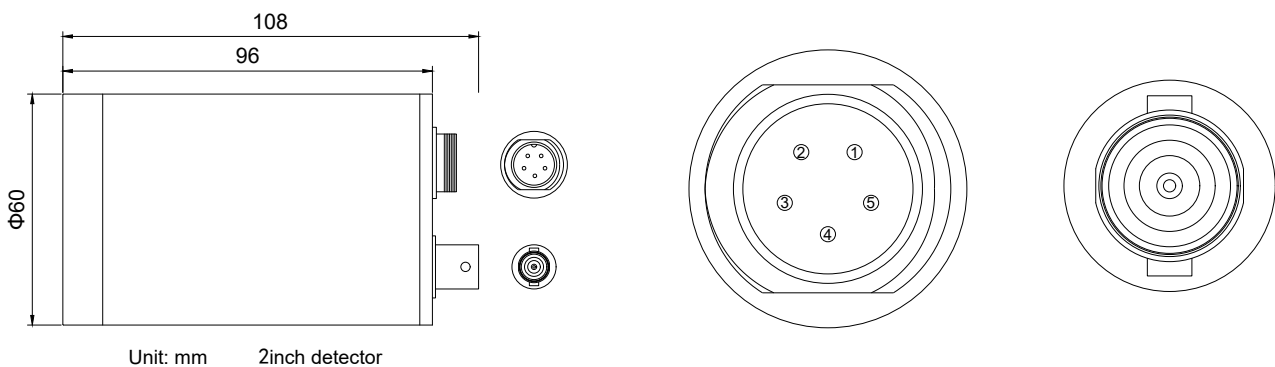

● Interface Definition

① Ground	② Power supply (+25.5V~+29.5V)
③ NC	④ NC
⑤ Temperature linear output (+0.1V~+2V) / (-40°C~150°C)	● BNC: Signal output